

Rigid Sound Attenuator

APPLICATION

The *Unico System* rigid sound attenuators are designed for close-coupled applications where it is desired to attach the outlets as close as possible to the plenum.

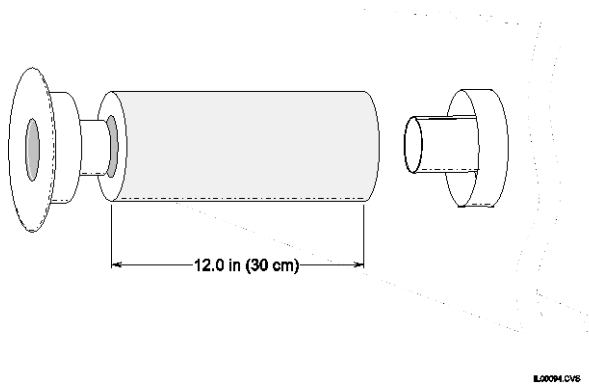

Figure 1. Rigid Sound Attenuator

They are ideal for older, historic buildings and churches, where the plenum may be located along the wall with the outlets pointed up or down. They are also well suited for masonry or concrete structures with no ceiling joists or a crawl space. In those cases, a plenum may be routed down the center of a hallway/corridor with the outlets connected directly to the plenum and discharging into the conditioned space next to the hallway/corridor.

The rigid attenuators and plenum may be boxed in for appearance. However, in some cases such as large auditoriums or restaurants the duct system may be left exposed and painted or covered for appearance. In these cases the terminator can be replaced with a tape ring (UPC-39) to dress up the outlet end of the rigid attenuator. The rigid attenuators are also designed for under-slab installations.

GENERAL

The *Unico System* rigid sound attenuator tubing is supplied in 12-inch (30-cm) lengths and is sold in kits (UPC-84, 85) that include all of the necessary components to install an outlet branch run. The attenuator may be cut to any length but not less than 8-inches (20 cm).

Figure 2 shows a typical center hall installation for both wood and masonry construction. After the duct system has been installed, a false ceiling can be constructed to conceal it.

Figure 3 shows a typical under-slab installation. A PVC coated spiral duct or PVC pipe must be used to prevent the deterioration or corrosion of the buried ductwork. Use a floor screen (UPC-88) to prevent object from falling into duct and blocking airflow.

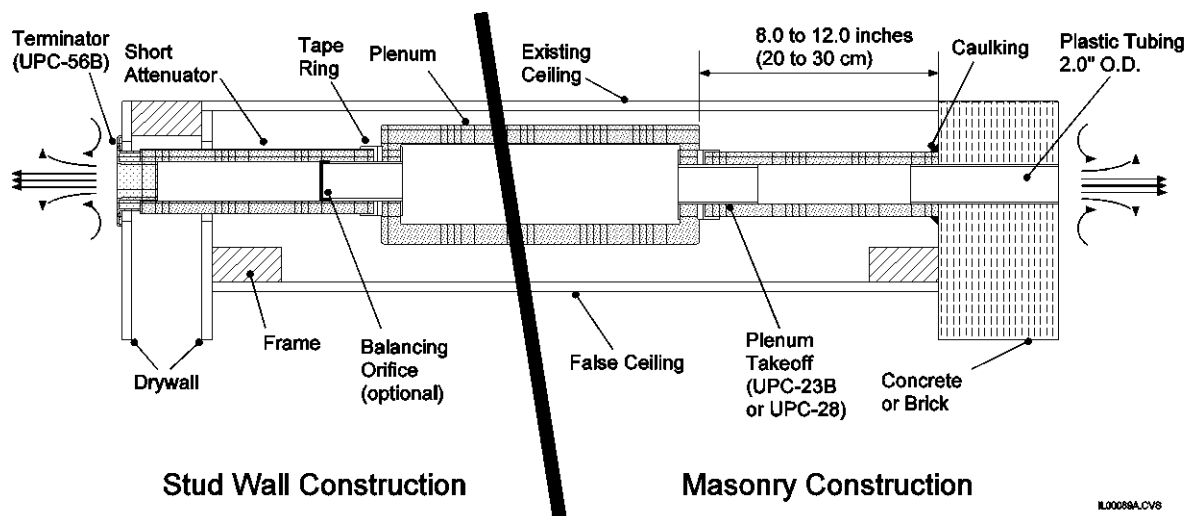

Figure 2. Typical Center Hall Installation

Since the outlet is much shorter than normal, they will deliver approximately 50 per cent more air than a normal full outlet. The increased airflow will allow fewer outlets to be used but the sound level will increase. If increased sound levels are not important, use 5 outlets per ton. Otherwise, it will be necessary to add a 15% balancing orifice on each plenum takeoff using 6 outlets per ton.

For installation instructions refer to Bulletin 30-061.

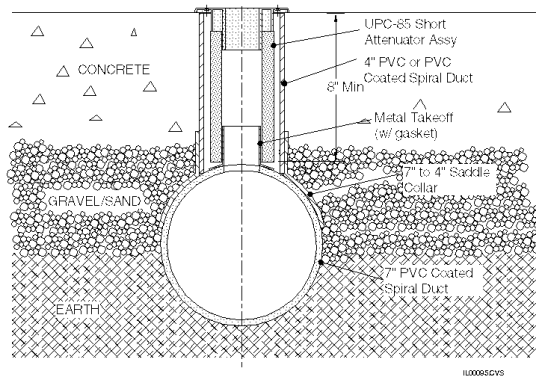

Figure 3. Typical Slab Installation